



TOWN OF DURHAM
8 NEWMARKET RD
DURHAM, NH 03824-2898

AUDREY CLINE
Zoning Administrator
Code Enforcement Officer
Health Officer

TEL: (603) 868-8064
acline@ci.durham.nh.us

Decision or Order of the Building Inspector/Code Enforcement Officer

175-12. Administrative Appeals.

Any person who believes that the Zoning Administrator has made an error in the interpretation or application of the provisions of this Ordinance, may appeal such determination to the Zoning Board of Adjustment as an administrative appeal under the provisions of Section 175-19. If the Board finds that the Zoning Administrator erred in his/her interpretation of the Ordinance, it shall modify or reverse the decision accordingly.

175.19. Powers and Duties

B. In exercising the above-mentioned powers, the Board may, in conformity with the provisions hereof, reverse or affirm, wholly or partly, or may modify the order, requirements, decision or determination appealed from and may make such order or decision as ought to be made and to that end shall have all the powers of the officer from whom the appeal is taken.

Applicant: Benjamin Segil, 26 Colony Cove Road, Durham NH 03824

Date of order: April 26, 2026

Deadline for application for appeal: May 5, 2025

Decision or Order of the Building Inspector/Code Enforcement Officer:

Building Permit Application number 26-00107, for property located at 26 Colony Cove Road, Durham; Map & Lot 217/11, is DENIED as the proposal does not meet the requirements of the Durham Zoning Ordinance below:

ARTICLE XII.1 USE AND DIMENSIONAL STANDARDS 175-54.

Table of Dimensions.

Minimum setback from each side property line 50'

ARTICLE XIV SHORELAND PROTECTION OVERLAY DISTRICT

175-74. Dimensional Requirements.

All land, buildings, and structures to be used, erected, altered, enlarged, or moved within the SPOD shall be in accordance with the dimensional standards of the underlying zoning district except as modified and required by this section.

A. Shoreland Setback of Buildings and Structures

Any new building or structure or any enlargement or modification of an existing building or structure shall be set back from the reference line of the waterbody as follows:

1. Great and Little Bays 125 feet

ARTICLE IX NONCONFORMANCE

175-30. Nonconforming Structures and Buildings.

D. Requirements for Nonconforming Buildings and Structures in the WCOD and SPOD.

3. The construction of attached additions or other expansions to nonconforming 1- and 2family dwellings shall be permitted within the Wetland Conservation Overlay District and Shoreland Protection Overlay District provided that:

c. The building footprint existing prior to the date on which this Article was enacted shall not be cumulatively increased by more than 15 percent.

d. The habitable floor area existing prior to the date on which this Article was enacted shall not be cumulatively increased by more than 30 percent.

By Durham's Building Inspector/Code Enforcement Officer:

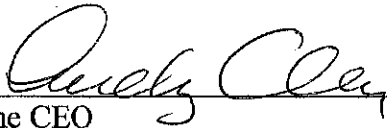

Audrey Cline CEO



TOWN OF DURHAM
 ZONING BOARD OF ADJUSTMENT
 8 NEWMARKET RD
 DURHAM, NH 03824
 PHONE: 603/868-8064
 www.ci.durham.nh.us

Fees \$415
 paid 4/21/26
 # 345

VARIANCE

Prior to seeking a variance, the property owner must have been denied a building permit by the Building Inspector or denied approval by the Planning Board.

Name of Applicant BENJAMIN SEGIL

Address: 216 COLONY COVE RD DURHAM NH

Phone # 603-534-1515 Email: bjsegil@gmail.com

Owner of Property Concerned SAME
 (If same as above, write "Same")

Address: SAME
 (If same as above, write "Same")

Location of Property: 216 COLONY COVE ROAD
 (Street & Number)

Tax Map & Lot number 217/11

A Variance is requested from Article(s) XII, I, XIV Section(s) 175-59, 175-74A1 of the Zoning Ordinance to permit: IX 175-30 B ctd

A NEW STRUCTURE ON A NON CONFORMING LOT W/IN THE SP0D

All applications must include a statement explaining how the applicant meets each of the five (5) statutory requirements for granting a variance, (A) through (E), which are found on page 2. The Zoning Board of Adjustment may consider the variance application incomplete if these five statements have not been addressed. In addition, all applications must be accompanied by adequate plans and exhibits.

Owner Authorization and Signature:

1. I/we do hereby authorize MICHAEL SIBERT & VERONICA file this application with the Zoning Board of Adjustment, to appear before the Board and to act on my/our behalf.
2. I/we do hereby authorize members of the Zoning Board of Adjustment and/or staff to enter upon the property on the afternoon prior to the Zoning Board meeting for purposes of reviewing this application.
3. To the best of my/our knowledge the information contained in this application is complete and accurate.

Owner's Signature(s): B. Segil Date: 4/21/2020

Owner's Signature(s): _____ Date: _____

PRINTED NAME(S): Benjamin Segil Date: 4/21/2020

PRINTED NAME(S): _____ Date: _____

RECEIVED
Town of Durham

APR 21 2026

Planning, Zoning
and Assessing

April 22, 2026

Neil Niman, Chair
Durham Zoning Board of Adjustment
8 Newmarket Road
Durham, NH 03824

Re: Benjamin Segil 26 Colony Cove Road Map 217 Lot 11

Dear Chair, Niman and Board Members:

Benjamin Segil of 26 Colony Cove Road is filing an application with the Zoning Board of Adjustment for variance relief. Based on a review of the proposed project with Audrey Cline Building Inspector we have determined that the following variances are required:

1. Article XII.1 Use and Dimensional Standards Section 175-54 Table of Dimensional Requirements for side setbacks and percent impervious surface.
2. Article XIV Shoreland Protection Overlay District Section 175-74A.1 minimum setback from the Highest Observable Tide Line.
3. Article IX Nonconformance Section 175-30D.3 c & d. Requirements for Nonconforming Buildings and Structures in the WCOD & SPOD. Maximum footprint expansion is 15% and maximum habitable space expansion is 30%.

EXISTING CONDITIONS

The subject parcel is located at 26 Colony Cove Road, consists of approximately 0.33 acres with 62'+/- of road frontage and 107'+/- water frontage on Little Bay. The lot has an average width of 56' and is 100' long. The use on the parcel is residential with an existing 86-year-old cottage, a garage and shed. There is a newly existing three-bedroom septic system between the house and garage. There is also a 100'+/- tidal dock with ramp and float.

THE PROPOSAL

The property owner purchased the parcel with the intent of making this his permanent long term residence. He is proposing to remove the existing structure and construct a new 2-1/2 story single family house. The proposed waterfront side of the house will be located about 2-3' further from the HOTL with the footprint expansion to the north and south sides of the proposed structure. The proposed structure is mostly in the same location on the parcel as the existing house. The reason for the footprint expansion on the sides is because these areas are currently developed. The north side is crushed stone without vegetation between the house and property line, and the south side has a brick walkway extending along the side, to the front of the house on the water side. The intent is to not encroach any further towards the shoreline or outside of these currently disturbed areas and center the house on the lot as closely as possible. The existing brick walkway along the south side of the existing house will be removed and terminate at the new entrance stairway, thereby reducing some of that existing impervious surface. We are confident that this proposal will have no greater impact to the surface water than the existing condition or than any other developed lot in the neighborhood. The reason for

our conclusion includes the house location being slightly further from the shoreline, expansion within previously disturbed areas and the addition of a stone drip strip along the waterfront side of the house to catch and treat roof runoff.

The variance application and supporting documentation are attached to this submission.

Thank you for the consideration and if you need additional information, please do not hesitate to contact me.

Sincerely,

Michael Sievert

Michael J. Sievert, P.E.

ADDENDUM A: APPLICATION FOR A VARIANCE -- Benjamin Segil 26 Colony Cove Road Map 217 Lot 11

A Variance is being requested from the zoning ordinance specific to Article XII.1 Use and Dimensional Standards Section 175-54 Table of Dimensional Requirements that applies to buildings and structures and Article XIV Shoreland Protection Overlay District Section 175-74 A.1 Shoreland Setback of Building and Structures. The specific request is for sideline setbacks and the setback from the Great Bay (highest observable tide line).

- 1) Granting the variance would not be contrary to the public interest because:
The applicability of the setbacks from the side property lines and the shoreland are there to minimize crowding of buildings and structures and minimize the environmental impact to the surface water. The lot is currently developed and is nonconforming with respect to these setbacks because the lot is an average of 56' wide therefore, the side setbacks overlap and do not provide any buildable area within the lot under the current regulations. The existing septic system and other accessory structures are located such that the building cannot meet the shoreland setback.
- 2) If the variance were granted, the spirit of the ordinance would be observed because: the lot was created and developed prior to the existing regulations and any reasonable building construction cannot meet all the required setbacks. The lot is currently developed in a similar layout to all other lots in the neighborhood. The proposal does not conflict with the proposed use and does not alter the essential character of the neighborhood or injure public rights.
- 3) Substantial justice would be done by granting the variance because: the expansion of the single-family home will not cause harm to the general public to any greater extent than the existing building therefore, substantial justice is done because a new updated single-family home is provided and the small increase in footprint does not harm the general public. Granting this variance would also allow a use that is consistent with the surrounding area.
- 4) If the variance were granted, the values of the surrounding properties would not be diminished because: the value of the new single-family home would be far greater than the value of the existing 86-year-old cottage, thereby maintaining the value of the surrounding properties.
- 5) (A) Owing to special conditions of the property that distinguish it from other properties in the area, denial of the variance would result in unnecessary hardship because:
 - a) no fair and substantial relationship exists between the general public purpose of the ordinance provision and the specific application of that provision to the property because: The property is unique in its slenderness which has resulted in its linear development. The purpose of the ordinance is to separate structures relative to each other and provide

an adequate setback from surface water. The average width of the lot is 56'+/-. Application of 50' side setbacks render the lot undevelopable without a variance. The 125' shoreland setback also cannot be met due to the historical development of the lot. There are two accessory buildings and a driveway outside of the shoreland setback so no additional structures will fit on the lot in this location and if this location was available on the lot, it would alter the character of the surrounding neighborhood. No other structures on waterfront lots in the Colony Cove neighborhood meet the 125' setback and several are closer to the HOTL. Relief can be granted to this property without upsetting the purpose because this proposed layout will maintain the integrity of the neighborhood of single-family homes of similar size and location with respect to the required setbacks and not cause a greater detriment to the surface water.

b) the proposed use is a reasonable one because: there is no other physical location on the property that would meet the strict regulations therefore this use is reasonable based on the neighborhood.

ADDENDUM B: APPLICATION FOR A VARIANCE – Benjamin Segll 26 Colony Cove Road Map 217 Lot 11

A Variance is being requested from the zoning ordinance specific to Article XII.1 Use and Dimensional Standards Section 175-54 Table of Dimensional Requirements that applies to buildings and structures and Article IX Nonconformance Section 175-30 D.3c. & d. Requirements for Nonconforming Buildings and Structures in the WCOD & SPOD. The specific request is for exceeding the percent impervious surface ratio and the allowable footprint expansion of 15% and habitable space expansion of 30%.

- 1) Granting the variance would not be contrary to the public interest because: It does not increase adverse impacts to surface waters, or neighboring properties beyond what already exists. Based on the plans, the lot is significantly constrained by tidal waters of Little Bay, wetland buffer requirements, shoreland buffer requirements and pre-existing nonconformities. The proposed construction replaces an 86-year-old existing cottage and occurs primarily within the already disturbed footprint, minimizing disturbance to protected natural resources. The project incorporates modern stormwater management and reduced runoff concentration compared to the existing conditions, which improves environmental protection relative to the current development. No public rights, safety or access are impaired. The increase in habitable space is vertical within the structure and will not add to the percent increase in impervious lot area. Accordingly, granting the variance serves the public interest by allowing reinvestment and environmental improvements on an already developed shoreline parcel without expanding impacts into undisturbed areas.
- 2) If the variance were granted, the spirit of the ordinance would be observed because: The spirit of the ordinance within the WCOD & SPOD is to protect water quality, prevent shoreline degradation and limit new intrusion into sensitive natural areas. The proposed design meets the spirit of the ordinance by avoiding new encroachment toward Little Bay, maintaining existing shoreline orientation and concentrating development in the least impactful portion of the site. The inability to meet dimensional requirements is the result of historic lot layout and shoreline geometry, not disregard for the regulations. The proposed building location reflects the only practical area of the lot where a residence can be reasonably sited while respecting setbacks to the greatest extent feasible. The proposed increased footprint results in only a 2% increase in impervious surface area for the lot, and the habitable space increase does not impact the impervious surface increase. Granting the variance allows the ordinance's environmental goals to be met while recognizing the physical reality of this constrained shoreline lot; therefore, the essential character of the neighborhood is not altered.
- 3) Substantial justice would be done by granting the variance because: Denial of the variance would deprive the owner of a reasonable opportunity to modernize and safely occupy a residential structure on a legally existing lot, while granting the variance causes no measurable harm. Comparable nearby properties in Colony Cove exhibit similar constraints and shoreline relationships, and the

proposed building scale is consistent with surrounding development. Requiring strict compliance would impose an unreasonable burden unique to this parcel, whereas granting the variance enables a reasonable residential use with no offsetting public detriment.

- 4) *If the variance were granted, the values of the surrounding properties would not be diminished because:* The project replaces an outdated cottage with a modern code-compliant home that is visually compatible with the neighborhood character along Colony Cove Road. Removal of older structures enhance the appearance of the property and the neighborhood as a whole, thereby maintaining or improving surrounding property values, not diminishing them.
- 5) (A) *Owing to special conditions of the property that distinguish it from other properties in the area, denial of the variance would result in unnecessary hardship because:*

a) no fair and substantial relationship exists between the general public purpose of the ordinance provision and the specific application of that provision to the property because: The property is unique in its slenderness and size. The purpose of the ordinance is to minimize impervious surfaces to protect the adjacent surface waters from negative environmental impacts and minimize shoreline erosion. This restriction does not serve that purpose in a fair and substantial way because this minimal increase in footprint will not create a substantial negative impact to the adjacent surface water or the shoreline. The increased footprint occurs primarily within the disturbed lot area and is slightly increasing the shoreland setback. A new stormwater control system is being added to the waterfront of the building to collect, treat and disperse the runoff from the roof through the soil. Relief can be granted to this property without upsetting the purpose because protection of the surface water, the shoreline bank and existing natural areas are maintained.

b) the proposed use is a reasonable one because: the proposed redevelopment will not cause a negative environmental impact to the surface waters or shoreline to a greater extent than the adjacent properties, therefore this is a reasonable use of the parcel.

BENJAMIN SEGIL

SITE PLAN

DURHAM, NEW HAMPSHIRE

APRIL 2026

RECEIVED
Town of Durham

APR 21 2026

Planning, Zoning
and Assessing

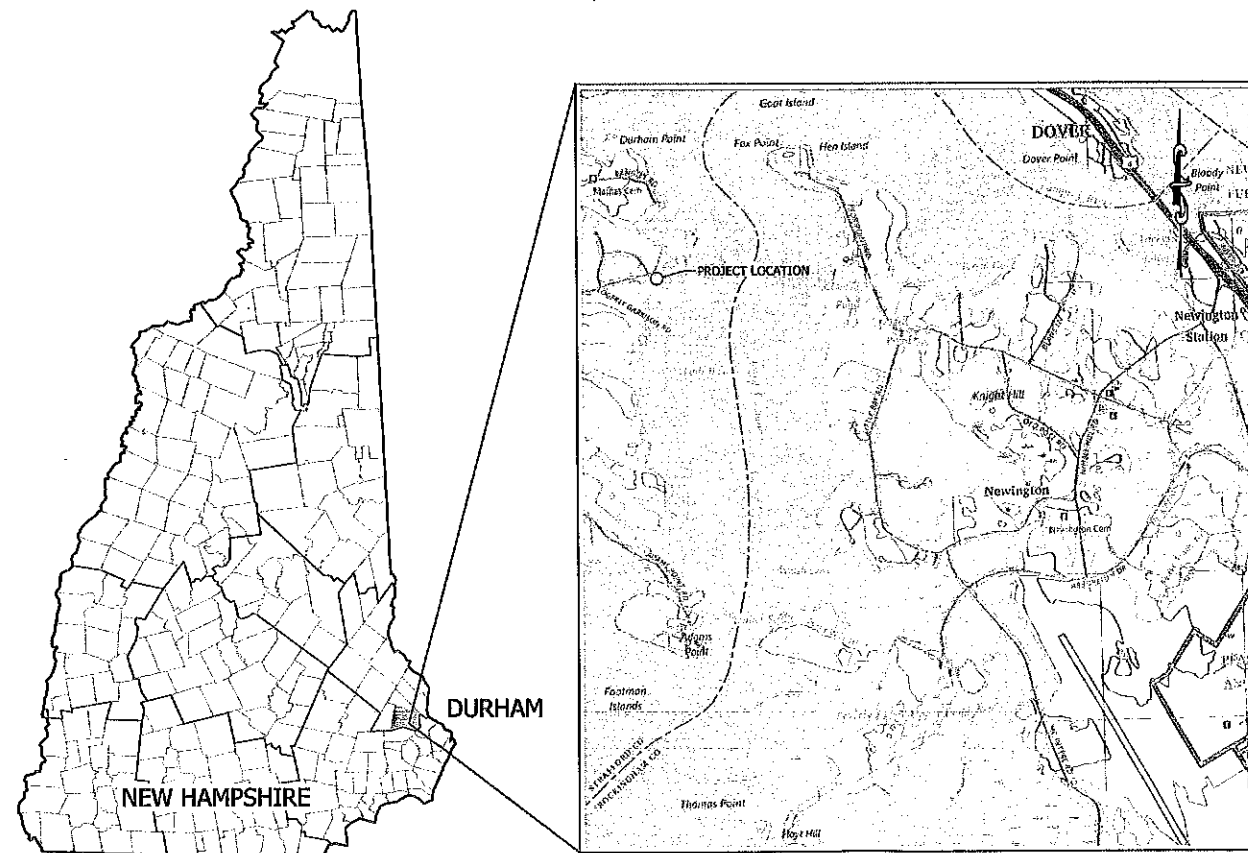

LOCATION PLAN

SCALE: 1" = 2000'

WE CERTIFY THAT THE DURHAM PLANNING BOARD GAVE THIS
SITE PLAN FINAL APPROVAL ON
AND THAT THE BOARD FOUND THAT ALL CONDITIONS
PRECEDENT TO FINAL APPROVAL HAD BEEN SATISFIED.

FINAL SITE PLAN
APPROVED
PLANNING BOARD
Durham, New Hampshire

OWNER SIGNATURES:

DATE: _____

OWNER/CLIENT:

BENJAMIN SEGIL
33 DEER STREET, UNIT 504
DURHAM, NH 03603
(603) 534-1515

ENGINEER & SURVEYOR:

verdantas
34 SCHOOL STREET
LITTLETON, NH 03561
(603) 444-4111

SHEET INDEX

CIVIL
1 OF 1 COVER
C 2.0 BOUNDARY SURVEY
OVERALL SITE PLAN

ARCHITECTURAL
A1.01 FLOOR PLANS
A2.00 EXTERIOR ELEVATIONS
3D 3D VIEWS

t:\proj_2026\260265_ben segil_26_colony_road_durham_nh_site_plan\intermediate\concepts\260265_concept-01.dwg 4/21/2026 10:17 AM

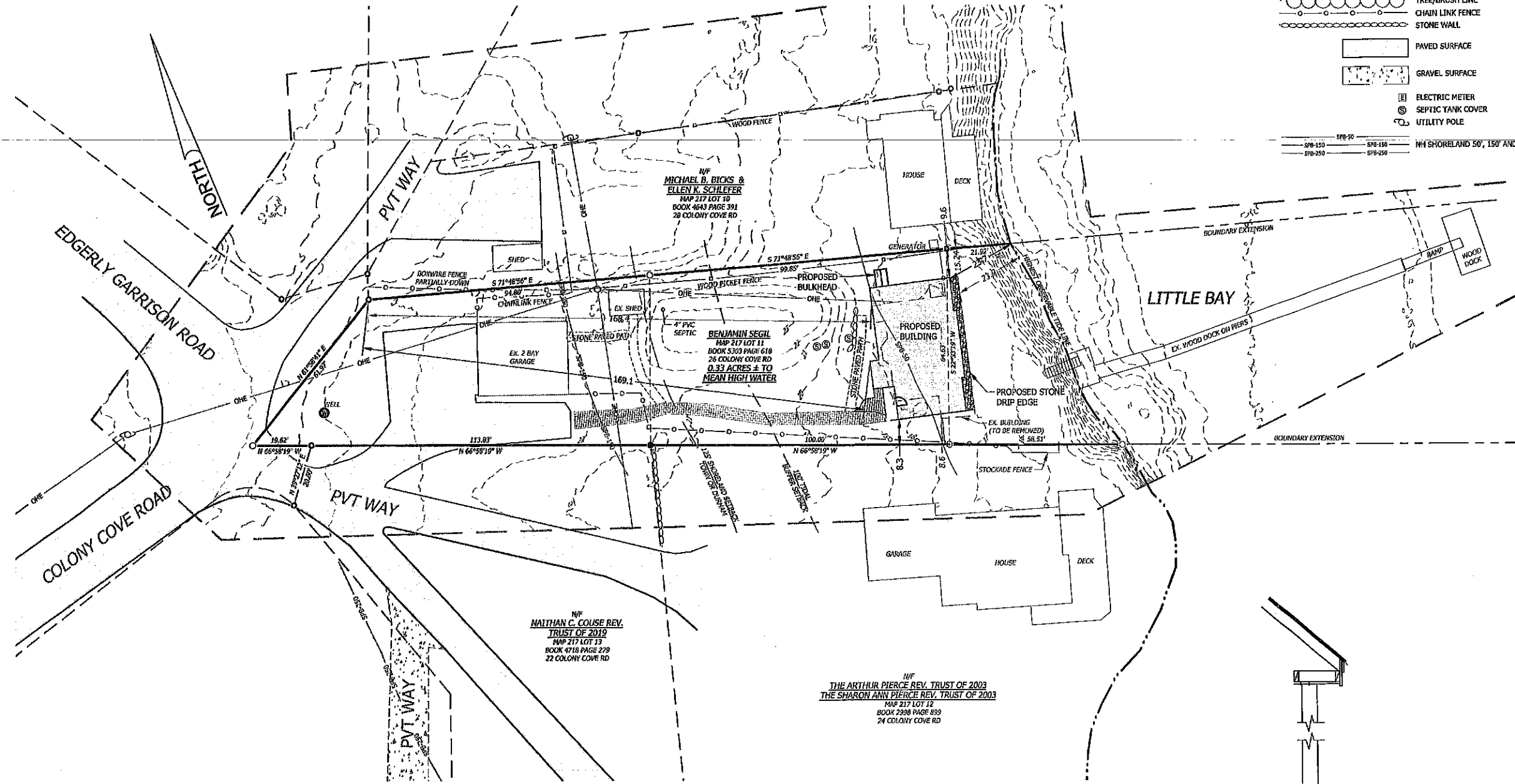

LEGEND

- IRON PIPE OR ROD FOUND
- CALCULATED CORNER
- PROPERTY LINE
- - - MAJOR CONTOUR (5')
- - - MINOR CONTOUR (1')
- - - APPROX. ABUTTING PROPERTY LINE
- - - HIGHEST OBSERVABLE TIDE LINE
- - - LIMIT OF FIELD TOPOGRAPHY
- OHE OVERHEAD UTILITIES
- TREE/BRUSH LINE
- CHAIN LINK FENCE
- STONE WALL
- ▭ PAVED SURFACE
- ▭ GRAVEL SURFACE
- ⊞ ELECTRIC METER
- ⊞ SEPTIC TANK COVER
- ⊞ UTILITY POLE
- NH SHORELAND 50', 150' AND 250' SETBACKS

| ZONING TABLE | | | |
|--------------------------|--------------|-----------------|----------------|
| MIN. LOT SIZE | REQUIRED | EXISTING | PROPOSED |
| | 150,000 S.F. | 14,375 S.F. | - |
| MIN. FRONTAGE | 300' | 61.97' | - |
| MIN. FRONT SETBACK | 30' | 168' | 169' |
| MIN. SIDE & REAR SETBACK | 50' | N - 15', S - 8' | N - 9', S - 8' |
| MIN. SHORELAND FRONTAGE | 200' | 103.7' | - |
| MAX. BUILDING HEIGHT | 30'/35' | 16' ± | 35' |
| MAX. IMPERVIOUS | 20% | 29.4% | 31.5% |
| MIN. SHORELAND SETBACK | 125' | 23' | 23' |

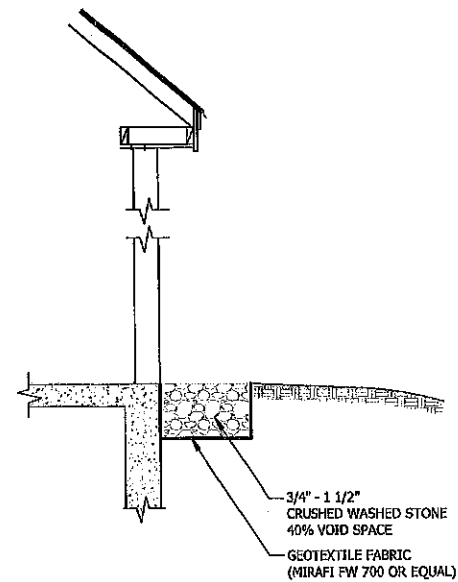

STONE DRIP EDGE DETAIL
NOT TO SCALE

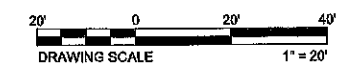

verdantas

34 SCHOOL STREET
LITTLETON, NH 03861
FAX: 603.444.1343
PHONE: 603.444.4111

ENGINEER'S NAME

STATE: XXXXXX P.E. #XXXX

DESIGNED BY
XXX

CHKD BY
DATE

DRAWN BY
XXX

CHECKED BY
XXX

PROJECT NO.
260265

REVISION

**PRELIMINARY
NOT FOR
CONSTRUCTION**

No.

DURHAM-NEW HAMPSHIRE
**BENJAMIN SEGIL
SITE DEVELOPMENT
PROPOSED SITE PLAN**

DATE
04/17/2026

SCALE
1" = 20'

SHEET

C2.0

