

GENERAL NOTES:
 THIS PLAN HAS BEEN PREPARED TO INDICATE THE PROPOSED WETLAND IMPACT CAUSED BY THE INSTALLATION OF A PRIVATE DRIVEWAY SERVING 3 RESIDENTIAL LOTS. SEE REFERENCE PLAN #1 FOR SUBDIVISION AND EASEMENT INFORMATION. DRIVEWAY SHOWN IS INTENDED TO INDICATE THE ASSUMED LAYOUT AS SKETCHED BY SFC ENGINEERING AND REVIEWED BY THE TOWN. FINAL DRIVEWAY LAYOUT TO BE DETERMINED BY SFC ENGINEERING AND DURHAM FIRE CHIEF.

REFER TO APPROVED SUBDIVISION PLAN FOR ALL BOUNDARY AND EASEMENT INFORMATION. INDICATIONS OF BOUNDARY LINES AND EASEMENT LOCATIONS SHOWN HEREON ARE FOR WETLAND IMPACT APPROXIMATION ONLY.

REFERENCE PLANS:

- "SUBDIVISION & LOT LINE ADJUSTMENT PLAN OF PROPERTY BY THE NAME OF COUNTY LINE HOLDINGS LLC & MARK D. MORONG 1991 TRUST" PREPARED BY DAVID W. VINCENT, LLS, LAND SURVEYING SERVICES, DATED FEBRUARY 3, 2014, UNRECORDED.

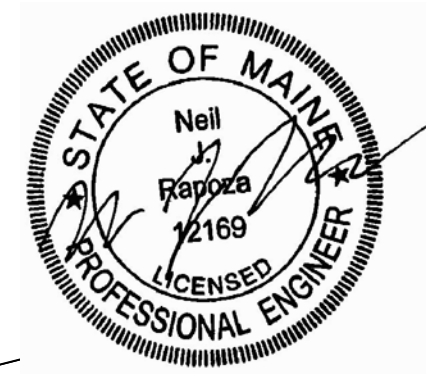
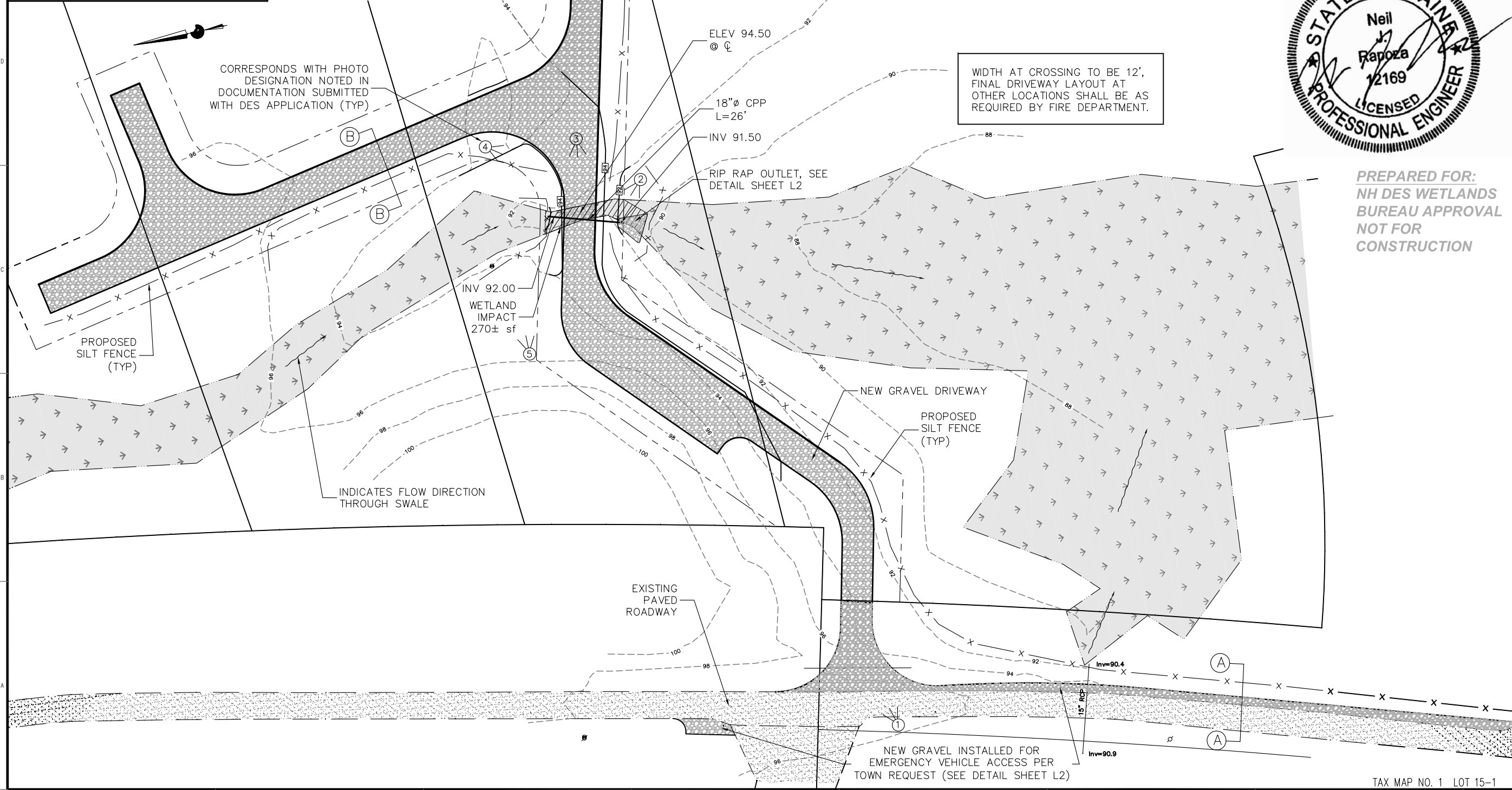
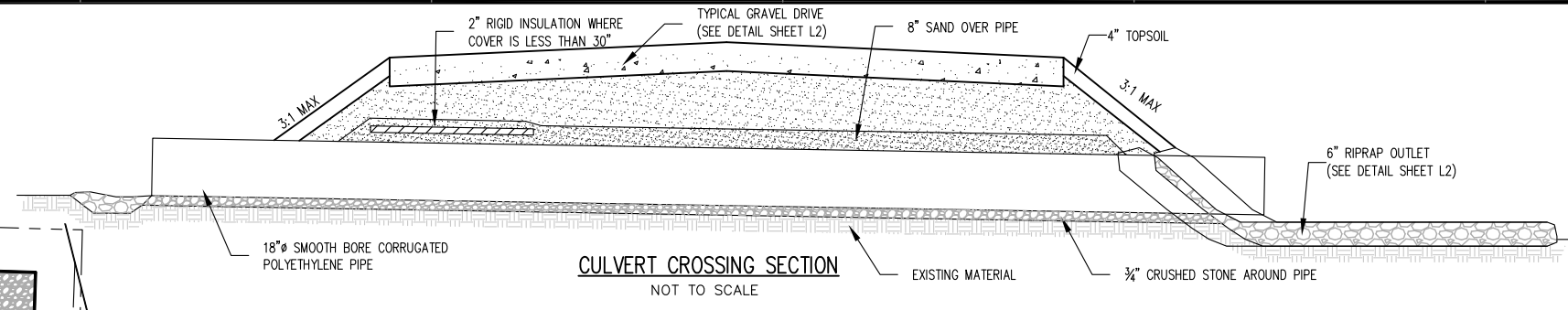

PREPARED FOR:
 NH DES WETLANDS
 BUREAU APPROVAL
 NOT FOR
 CONSTRUCTION

© CIVIL CONSULTANTS
CIVIL CONSULTANTS
 Engineers
 Planners
 Surveyors
 P.O. Box 100
 South Berwick
 Maine
 03908
 207-384-2550
 www.civcon.com

NO.	REVISIONS	DATE
2	ADDED ELEC. CABLE, SEWER, WATER DETAILS	4/30/15
1	MODIFIED EASEMENT/ADDED SECTIONS TO L1	4/21/15

RECORD OWNER:
 COUNTY LINE HOLDINGS, LLC.
 OWNER ADDRESS:
 8 LITTLE JOHN ROAD
 DURHAM, NH 03824

**NHDES WETLANDS BUREAU
 MINIMUM IMPACT EXPEDITED PERMIT APPLICATION
 PRIVATE DRIVE CROSSING
 EDGEWOOD ROAD EXT., DURHAM, NEW HAMPSHIRE**

PREPARED FOR:
 COUNTY LINE HOLDINGS, LLC.
 CLIENT ADDRESS: JOHN FARRELL, 8 LITTLE JOHN RD, DURHAM, NH 03824

DATE: 3/17/2015
 DRAWN BY: NJR
 CHECKED BY: GRA
 APPROVED BY: GRA

WETLAND IMPACT SKETCH
 PROJECT NO: 14-299.00
L1
 SHEET: 1 OF 2

TAX MAP NO. 1 LOT 15-1

GENERAL NOTES:

THIS PLAN HAS BEEN PREPARED TO INDICATE THE PROPOSED WETLAND IMPACT CAUSED BY THE INSTALLATION OF A PRIVATE DRIVEWAY SERVING 3 RESIDENTIAL LOTS. SEE REFERENCE PLAN #1 FOR SUBDIVISION AND EASEMENT INFORMATION. DRIVEWAY SHOWN IS INTENDED TO INDICATE THE ASSUMED LAYOUT AS SKETCHED BY SFC ENGINEERING AND REVIEWED BY THE TOWN. FINAL DRIVEWAY LAYOUT TO BE DETERMINED BY SFC ENGINEERING AND DURHAM FIRE CHIEF.

REFER TO APPROVED SUBDIVISION PLAN FOR ALL BOUNDARY AND EASEMENT INFORMATION. INDICATIONS OF BOUNDARY LINES AND EASEMENT LOCATIONS SHOWN HEREON ARE FOR WETLAND IMPACT APPROXIMATION ONLY.

REFERENCE PLANS:

- "SUBDIVISION & LOT LINE ADJUSTMENT PLAN OF PROPERTY BY THE NAME OF COUNTY LINE HOLDINGS LLC & MARK D. MORONG 1991 TRUST" PREPARED BY DAVID W. VINCENT, LLS, LAND SURVEYING SERVICES, DATED FEBRUARY 3, 2014, UNRECORDED.

EROSION AND SEDIMENT CONTROL PRACTICES

- NO SOIL SHALL BE DISTURBED DURING THE PERIOD OF MARCH 1 THROUGH APRIL 15, NOR DURING ANY OTHER PERIOD WHEN SOILS ARE SATURATED DUE TO RAIN OR SNOW MELT.
- DISTURBED SOILS SHALL BE STABILIZED WITHIN ONE (1) WEEK FROM THE TIME IT WAS LAST ACTIVELY WORKED USING TEMPORARY OR PERMANENT MEASURES SUCH AS PLACEMENT OF RIPRAP, MULCH OR EROSION CONTROL BLANKET, OR OTHER COMPARABLE MEASURES.
- HAY OR STRAW MULCH SHALL BE APPLIED AT A RATE OF AT LEAST ONE (1) BALE PER 500 SQUARE FEET (1-2 TONS PER ACRE).
- IF MULCH IS LIKELY TO BE REMOVED DUE TO TO STEEP SLOPES OR WIND, IT SHALL BE ANCHORED WITH NETTING, PEG OR TWINE, OR OTHER SUITABLE METHOD AND SHALL BE MAINTAINED UNTIL A CATCH OF VEGETATION IS ESTABLISHED OVER THE ENTIRE DISTURBED AREA.
- IN ADDITION TO PLACEMENT OF RIPRAP, MULCH OR EROSION CONTROL BLANKETS, ADDITIONAL STEPS SHALL BE TAKEN WHERE NECESSARY IN ORDER TO PREVENT SEDIMENTATION OF THE WATER. EVIDENCE OF SEDIMENTATION INCLUDES VISIBLE GULLY EROSION, DISCOLORATION OF WATER BY SUSPENDED PARTICLES AND SLUMPING OF BANKS, SILT FENCES, STAKED HAY BALES AND OTHER SEDIMENTATION CONTROL MEASURES, WHERE PLANNED FOR, SHALL BE IN PLACE PRIOR TO COMMENCEMENT OF WORK, BUT SHALL ALSO BE INSTALLED WHEREVER NECESSARY DUE TO SEDIMENTATION.
- MULCH OR OTHER TEMPORARY MEASURES SHALL BE MAINTAINED UNTIL THE SITE IS PERMANENTLY STABILIZED WITH VEGETATION OR OTHER PERMANENT CONTROL MEASURES AFTER WHICH TEMPORARY MEASURES WILL BE REMOVED.
- PERMANENT RE-VEGETATION OF ALL DISTURBED AREAS, USING NATIVE PLANT MATERIAL WHEN POSSIBLE, SHALL OCCUR WITHIN 30 DAYS FROM THE TIME THE AREAS WERE LAST ACTIVELY WORKED, OR FOR FALL AND WINTER ACTIVITIES, BY JUNE 15, EXCEPT WHERE PRECLUDED BY THE TYPE OF ACTIVITY (E.G. RIPRAP, ROAD SURFACES, ETC.). THE VEGETATIVE COVER SHALL BE MAINTAINED.
- DISPOSAL OF COLLECTED DEBRIS MUST BE IN CONFORMANCE WITH MAINE SOLID WASTE LAW, TITLE 38 MRSA SECTION 1301 ET. SEQ.
- LIME AND FERTILIZER APPLICATION RATES SHALL NOT EXCEED THE FOLLOWING:

GROUND LIMESTONE: 3 TONS/ACRE (130 LBS./1000 S.F.)
FERTILIZER, 10-10-10 OF EQUIVALENT: 600 LBS./ACRE (14 LBS./1000 S.F.)

FERTILIZER SHALL NOT BE APPLIED BEFORE START OF THE GROWING SEASON NOR AFTER SEPTEMBER 30. FERTILIZED AREAS SHALL BE MULCHED TO REDUCE OFF-SITE TRANSPORT OF NUTRIENTS UNTIL USED BY VEGETATIVE GROWTH.

FERTILIZER SHALL NOT BE APPLIED BEFORE START OF THE GROWING SEASON NOR AFTER SEPTEMBER 30. FERTILIZED AREAS SHALL BE MULCHED TO REDUCE OFF-SITE TRANSPORT OF NUTRIENTS UNTIL USED BY VEGETATIVE GROWTH.

SEEDING MIXTURE AND SCHEDULE:

SPREAD TOPSOIL UNIFORMLY 6" DEEP OVER AREAS TO BE RECLAIMED. THE FOLLOWING SEED MIXTURE SHALL BE USED:

LAWNS:

KENTUCKY BLUEGRASS	0.46 LBS./1000 S.F.
CREeping RED FESCUE	0.46 LBS./1000 S.F.
PERENNIAL RYE GRASS	0.11 LBS./1000 S.F.
TOTAL	1.03 LBS./1000 S.F.

APPLY LIME AND FERTILIZER AS SPECIFIED UNDER THE EROSION AND SEDIMENTATION CONTROL NOTES. WORK INTO THE TOP (4) INCHES OF SOIL PRIOR TO SEEDING. AFTER SEEDING, APPLY MULCH HAY AS SPECIFIED. ON FLAT AREAS AND NOT EXPOSED TO WIND, THE MULCH WILL BE ANCHORED BY WETTING DOWN. IN OTHER AREAS, JUTE NETTING SHALL BE USED FOR ANCHORAGE. THE ABOVE SEEDING SCHEDULE IS APPLICABLE IF SEEDING DURING THE GROWING SEASON (APRIL 15 TO JUNE 15 AND AUGUST 30 TO SEPTEMBER 30). BETWEEN JUNE 15 AND AUGUST 30, SEEDING WILL BE DELAYED UNTIL AUGUST 30. IF SOIL IS DISTURBED BETWEEN OCTOBER 1 AND NOVEMBER 1, DELAY SEEDING UNTIL NOVEMBER 1. AFTER NOVEMBER 1 AND BEFORE A SNOW COVER FORMS, THE SAME PROCEDURE WILL BE FOLLOWED EXCEPT THE SEED RATE WILL BE DOUBLED. AFTER SNOW COVER AND BEFORE APRIL 15, SEEDING WILL BE DELAYED UNTIL APRIL 15. HAY MULCH WILL BE APPLIED AT A RATE OF 150 LBS./1000 SQUARE FEET. THIS WILL BE ANCHORED BY NON-ASPHALTIC TACKIFIER SPRAYED ON LAWNS AND JUTE NETTING IN DRAINAGE WAYS AND OTHER AREAS.

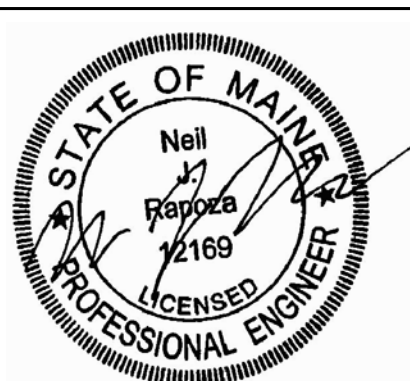
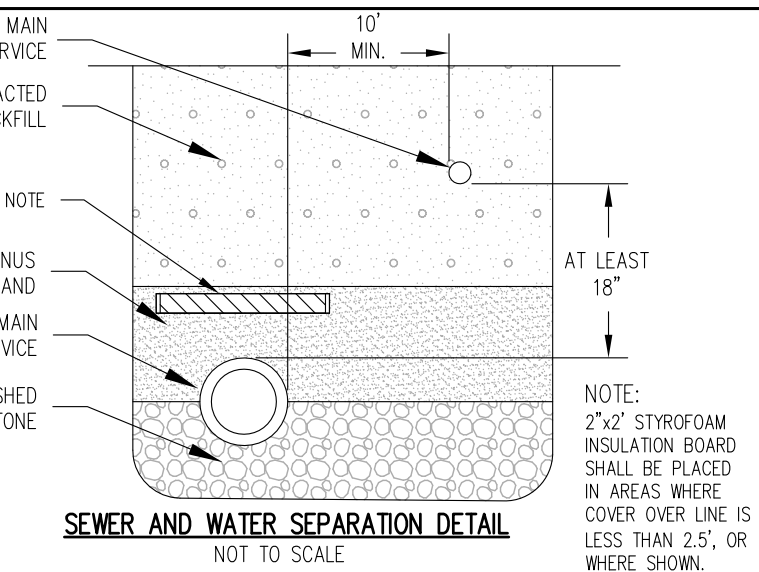
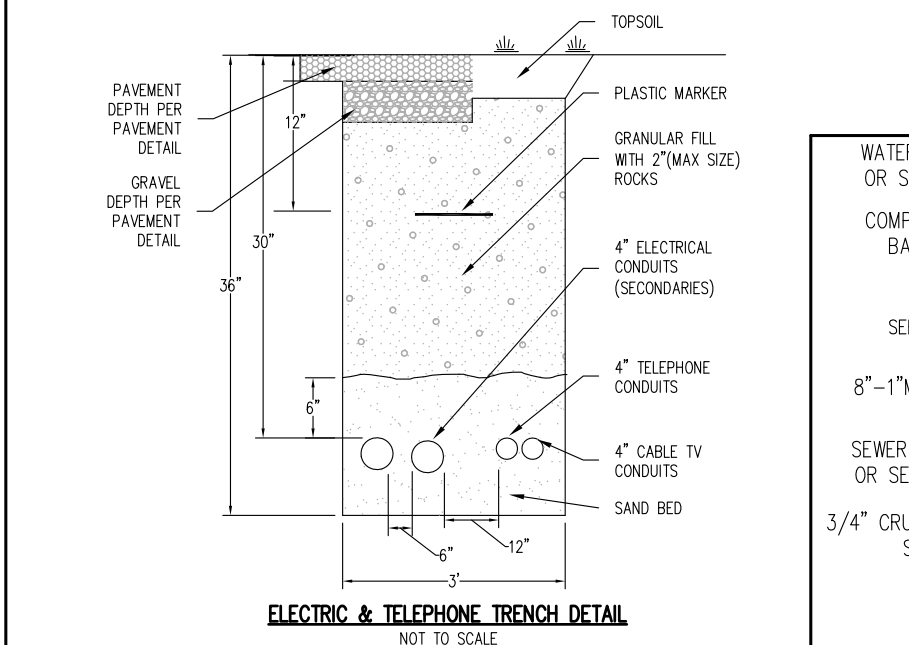
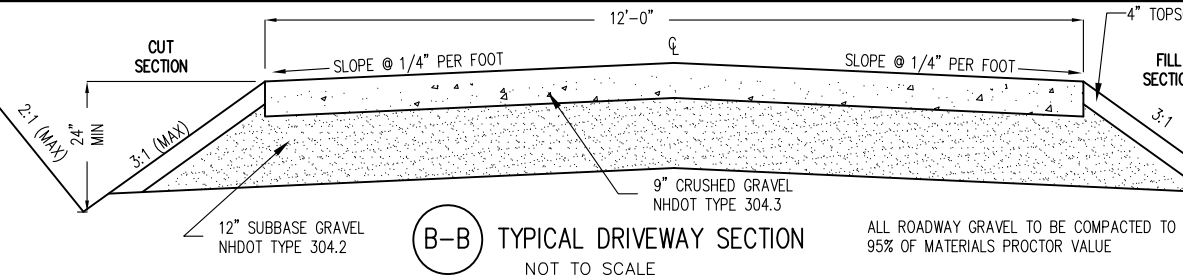
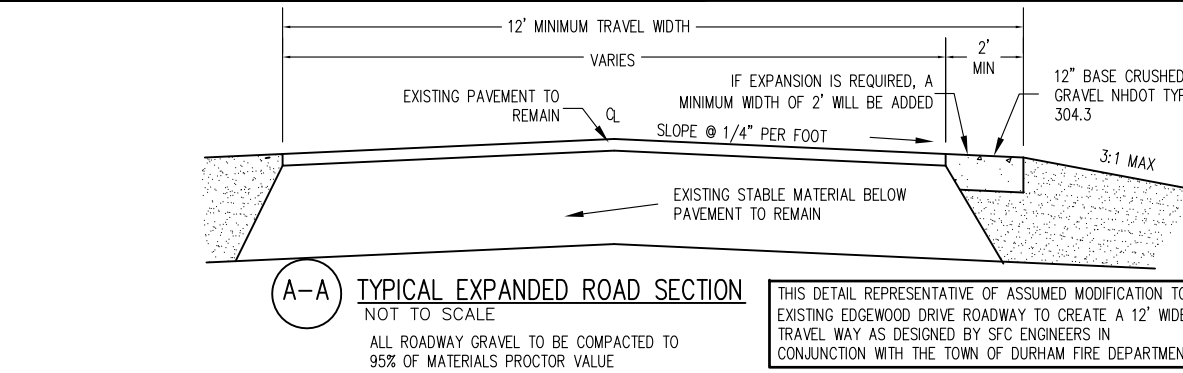
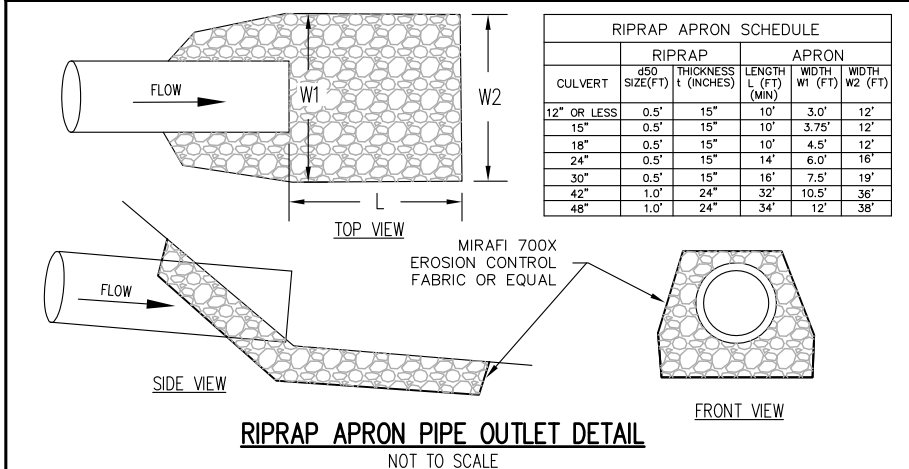
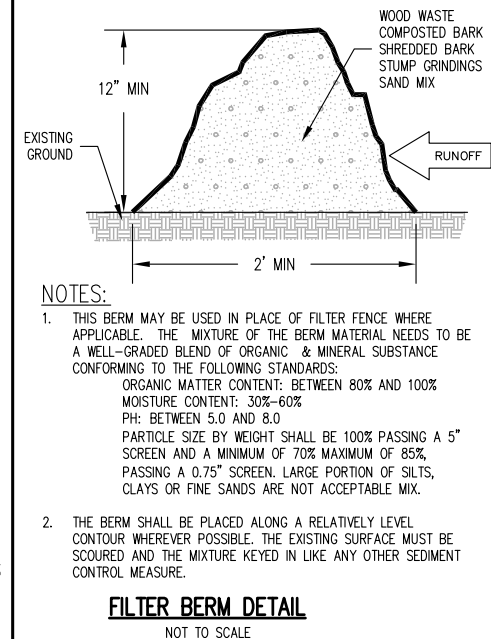
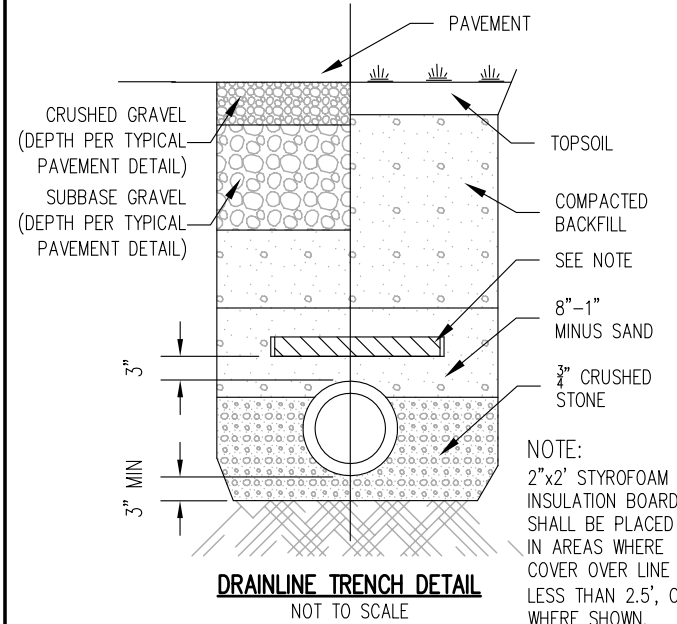
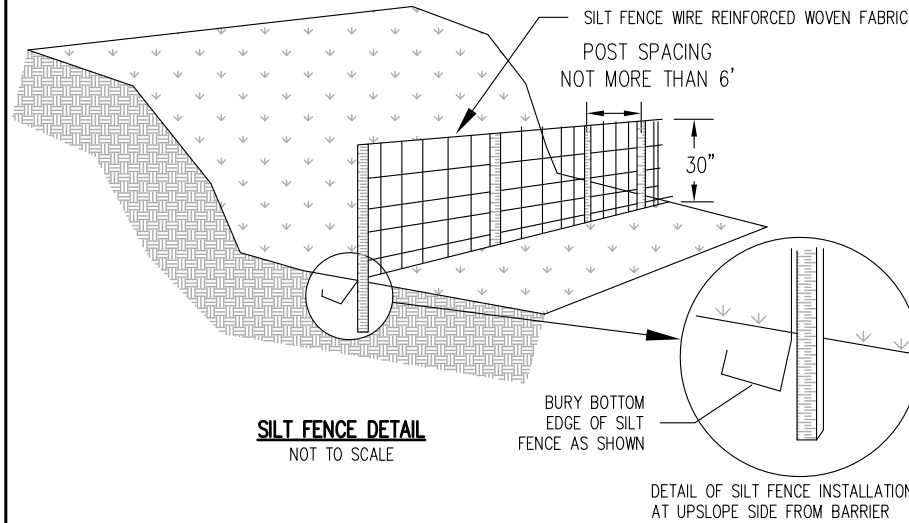

PREPARED FOR:
NH DES WETLANDS BUREAU APPROVAL
NOT FOR CONSTRUCTION

CIVIL CONSULTANTS
Engineers
Planners
Surveyors
P.O. Box 100
South Berwick
Maine
03908
207-384-2550
www.civcon.com

RECORD OWNER: COUNTY LINE HOLDINGS, LLC.
OWNER ADDRESS: 8 LITTLE JOHN ROAD DURHAM, NH 03824

NH DES WETLANDS BUREAU MINIMUM IMPACT EXPEDITED PERMIT APPLICATION PRIVATE DRIVE CROSSING EDGEWOOD ROAD EXT., DURHAM, NEW HAMPSHIRE

PREPARED FOR: COUNTY LINE HOLDINGS, LLC.
CLIENT ADDRESS: JOHN FARRELL, 8 LITTLE JOHN RD, DURHAM, NH 03824

DATE: 3/17/2015
DRAWN BY: NJR
CHECKED BY: GRA
APPROVED BY: GRA

NOTES AND DETAILS

PROJECT NO: 14-299.00

L2

SHEET: 2 OF 2

TAX MAP NO. 1 LOT 15-1